

INSTALLATION INSTRUCTIONS



TACOMA COLD AIR INTAKE KIT-50 STATE LEGAL

180322-1-KIT (1995-2000 TACOMA/4RUNNER, 2.7L 4CYL)

KIT CONTENTS





RECOMMENDED TOOLS

Flat Head Screwdriver
Drill with 5/16" Drill Bit
Ratchet & Socket set
Adjustable Wrench

CAUTION

1. Read all instructions completely and carefully before you begin.
2. Check to make sure the kit is complete and that no parts are missing (refer to the Kit Contents List on the first page of these instructions). If anything is missing, please contact Trail-Gear at 559.252.4950.
3. Park vehicle on a clean, dry, flat, level surface and block the tires so the vehicle can not roll in either direction.
4. Any variation from these instructions or parts will void the 50-state smog legal certification.

INSTALLATION INSTRUCTIONS



AIR INTAKE INSTRUCTIONS

STEP 1

Disconnect the Mass Airflow Sensor harness from the Mass Airflow Sensor.



STEP 2

Disconnect all hoses and air ducting between the engine and the stock Air Cleaner.



STEP 3

Unbolt and remove the entire Air Cleaner, Mass Airflow Sensor, Intake Air Connector, and Air Cleaner Hose with Resonator from the vehicle. Save the Mass Airflow Sensor and rubber gasket for reinstallation.

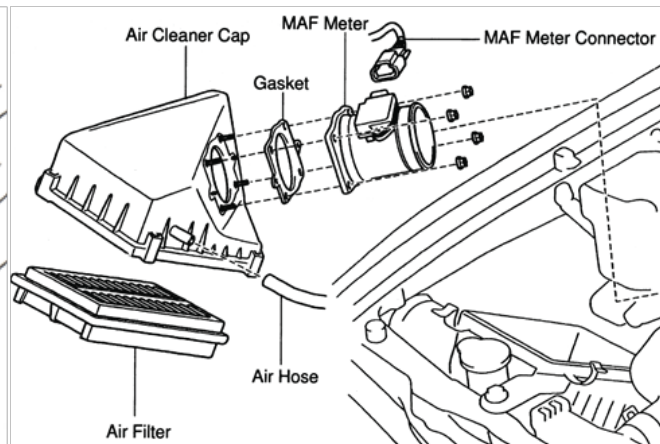
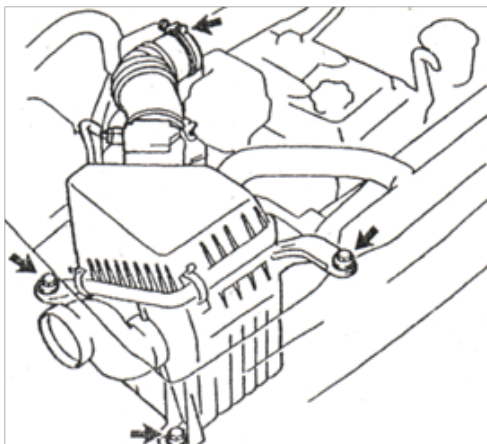
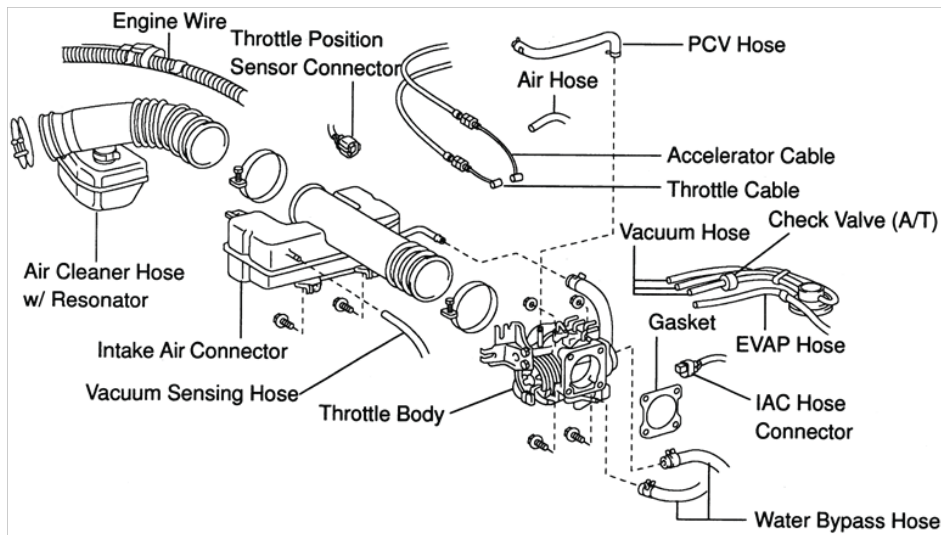

INSTALLATION INSTRUCTIONS



STEP 4

Position the new Air Intake Bracket into the stock Air Cleaner's mounting location. Align the long mounting leg of the new Air Intake Bracket with the original Air Cleaner's rear mounting hole. Mark this location on the Air Intake Bracket. Remove the Air Intake Bracket and drill a 5/16" diameter hole in the marked location on the Air Intake Bracket. Note: It might be necessary to mock up the Stainless Steel Air Tube, Cast Aluminum Air Tube, & Silicone Adapters in order to position the Air Intake Bracket correctly.



STEP 5

Position the Air Intake Bracket back into the vehicle and secure using the stock bolt or the M8 Bolt & 5/16" Washer provided.

STEP 6

Align the steel Support Bracket with the mounting hole in the Air Intake Bracket and against the flat spot on the inner fender panel. Mark the location and drill a 9/32" diameter mounting hole at the marked location on the inner fender panel. Note: In some instances, the support bracket may need to be slightly bent to align with the fender panel correctly.



STEP 7

Attach the Mass Airflow Sensor & rubber gasket removed in Step 3 to the back of the Air Intake Bracket using (4) of the 1/4" bolts and nuts provided.



INSTALLATION INSTRUCTIONS



STEP 8

If the vehicle is installed with a charcoal canister, install the Nylon 3/8" Barbed x 1/2" NPS Fitting into the corresponding 1/2" NPS hole in the Air Intake Bracket. If the vehicle is not equipped with a charcoal canister, install the 1/2" NPS plug into the 1/2" NPS hole in the Air Intake Bracket.



STEP 9

Mount the Air Intake Bracket and the Support Bracket back into the vehicle and secure using the remaining (2) 1/4" Bolts & Nylock Nuts.



STEP 10

Install the Stainless Steel Air Tube, Cast Aluminum Air Tube, Silicone Adapters, Fittings, & Hose Clamps per the diagram below. Note: If the stock hose coming from the Charcoal Canister is too short, replace it with the 11" long piece of 3/8" I.D. Rubber Tubing provided and secure it to the 3/8" Barbed Fitting on the Air Intake Bracket with the 5/8" Hose Clamp provided.

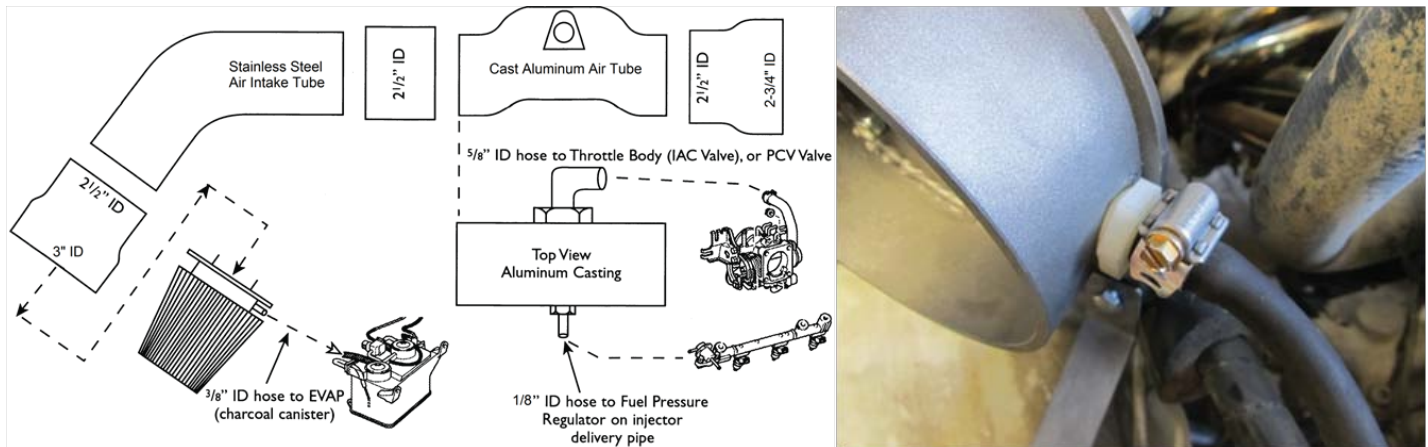

INSTALLATION INSTRUCTIONS



STEP 11

Install the Air Filter onto the Air Intake Bracket and secure the hose clamp provided on the Air Filter.



STEP 13

Apply the provided C.A.R.B. decal to the underside of the hood.

STEP 15

As needed, wash & re-oil the Air Filter using a commercially-available reusable filter recharger kit.

STEP 12

Connect the Mass Airflow Sensor Harness to the Mass Airflow Sensor.



STEP 14

Start the vehicle. If the Check Engine light stays lit, stop the engine and disconnect the battery. This will reset the engine computer and turn off the Check Engine light.